

PARTNo	L	W	T	MATL	COLOUR
400101	52	15.5	10	PP	WHITE
400102	52	15.5	10	PP	BROWN
400103	52	15.5	10	PP	BLACK
400121	51	16	12	PP	WHITE
400122	51	16	12	PP	BROWN
400123	51	16	12	PP	BLACK
400129	50	14	12	ABS	WHITE
400130	50	14	12	ABS	BROWN
400131	52	16	13	PP	WHITE
400132	52	16	13	PP	BROWN
400133	52	16	13	PP	BLACK
400151	52	16	15	PP	WHITE
400152	52	16	15	PP	BROWN
400153	52	16	15	PP	BLACK
410650	52	15	15	PP	WHITE

PARTNo	L1	W	T	L2	C1	C2	D
410240	40	25	12.5	17	5.5	7.2	5.5
410241	40	25	12.5	17	5.5	7.2	5.5
410242	40	25	12.5	17	5.5	7.2	5.5
410300	40	25	12.5	14	5.5	7.2	5.5
410301	40	25	12.5	14	5.5	7.2	5.5

PARTNo	MATL	COLOUR
410240	PP	WHITE
410241	PP	BROWN
410242	PP	BLACK
410300	PP	WHITE
410301	PP	BROWN

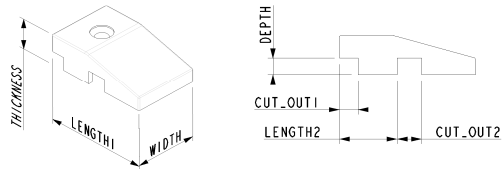

W =Width
T =Thickness
C1 = Cutout1
C2 = Cutout2
L =Length
L2 =Length 2
D = Depth

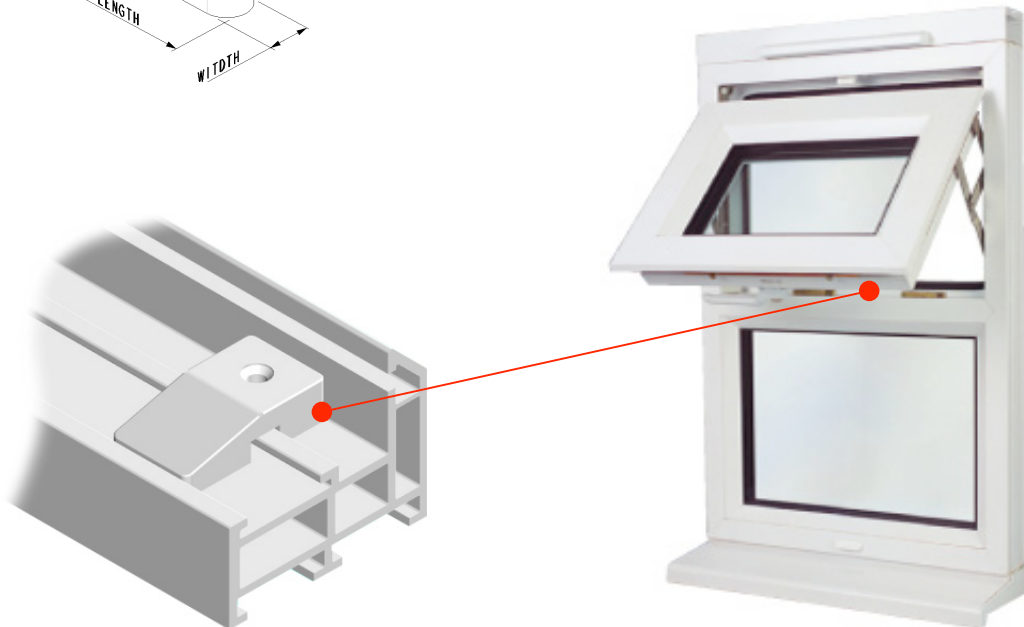
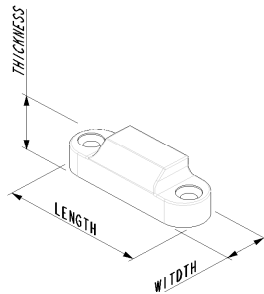

For more information visit:
www.glazpart.com

PARTNo	L	W	T	D	C	S	MATL	COLOUR
410251	46	25	12	6	9.5	15.5	PP	WHITE
410252	46	25	12	6	9.5	15.5	PP	BLACK
410253	46	25	12	6	9.5	15.5	PP	BROWN
410259	46	25	12	6	9.5	15.5	PA6	WHITE

PARTNo	L1	W	T	L2	D	C	MATL	COLOUR
410254	35	25	12	15	8	4	PP	WHITE
410255	35	25	12	15	8	4	PP	BLACK
410256	35	25	12	15	8	4	PP	BROWN

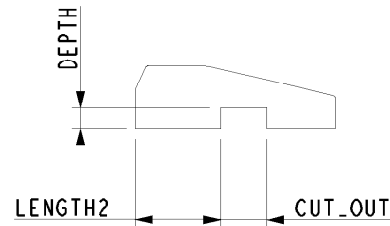
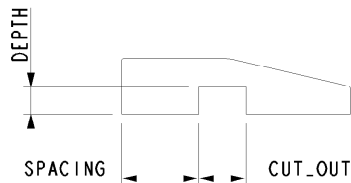
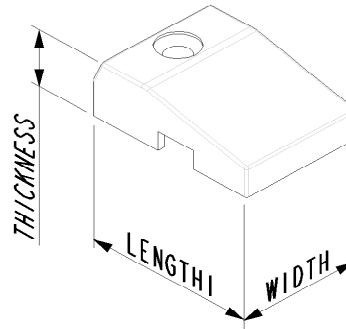
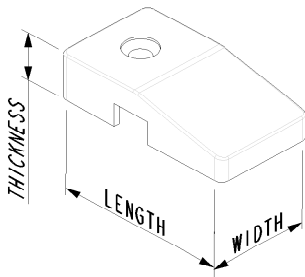

W =Width
T =Thickness
C1 = Cutout1
C2 = Cutout2
L =Length
L2 = Length2
D = Depth

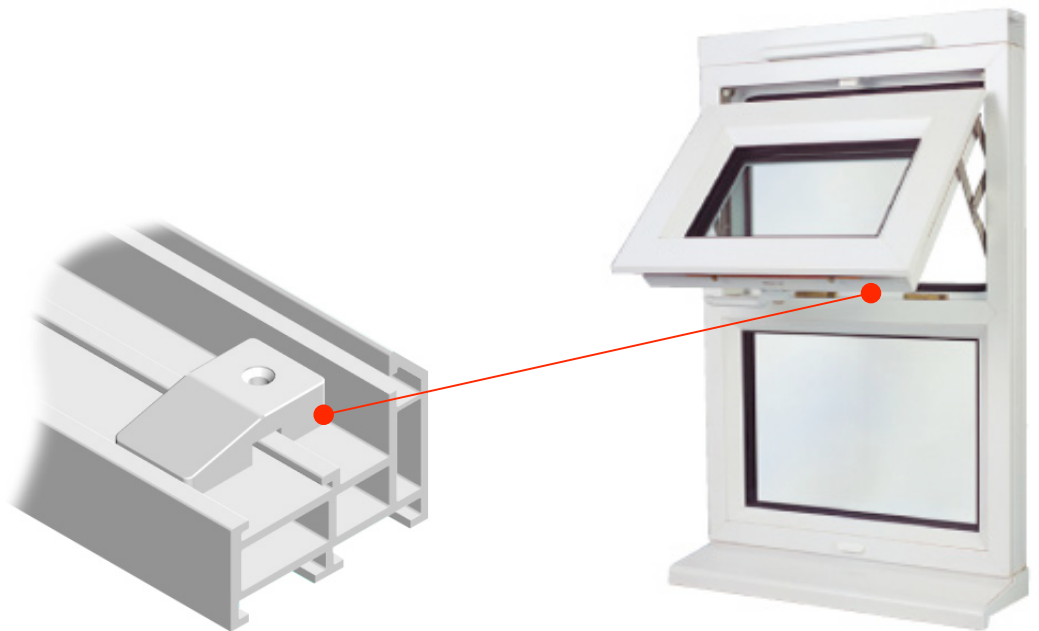

For more information visit:
www.glazpart.com

PARTNo	L	W	T	D	C	MATL	COLOUR
410257	38.5	30	16.6	3.5	13.5	PP	BROWN
410258	38.5	30	16.6	3.5	13.5	PP	WHITE

PARTNo	L	W	T	D1	D2	D3	C1	C2
410441	34.5	25	12	7	5	7	2.5	29.4

PARTNo	S1	S2	MATL	COLOUR
410441	20	3.8	PP	WHITE

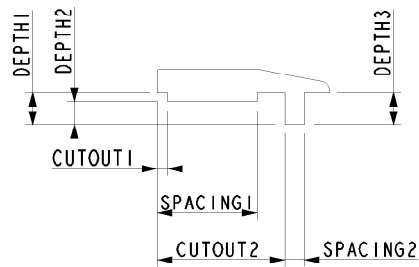
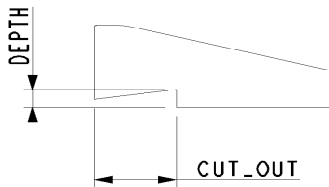
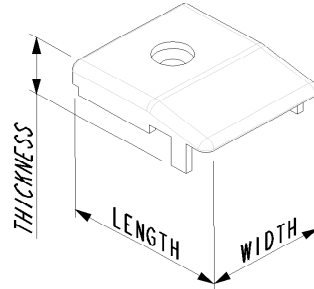
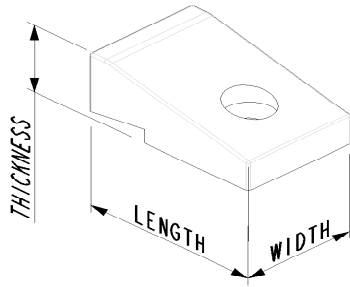

- W =Width**
- D1 =Depth1**
- D2 = Depth2**
- D3 = Depth3**
- T =Thickness**
- L =Length**
- S1 =Spacing 1**
- S2 = Spacing 2**
- C1 =Cutout1**
- C2 =Cutout2**

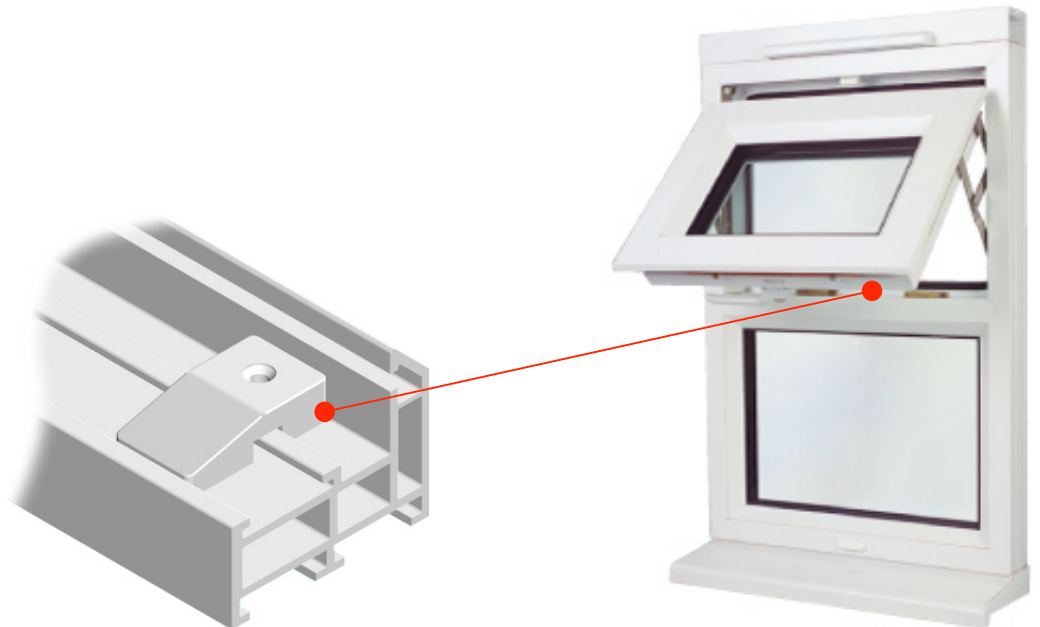

For more information visit:
www.glazpart.com

PARTNo	L	W	T	D1	D2	D3	S1	S2
410630	46.5	30	14.3	4.5	3	5	5	35
410631	46.5	30	14.3	4.5	3	5	5	35
410720	55	25	15.5	2	3	3	24	39
410721	55	25	15.5	2	3	3	24	39

PARTNo	L	W	T	D1	D2	D3	S1	S2	C
410261	44.5	28	20	8.5	3.8	8	16	12	12

PARTNo	MATL	COLOUR
410261	PP	WHITE

PARTNo	C1	C2	MATL	COLOUR
410630	27	3	PP	WHITE
410631	27	3	PP	BROWN
410720	3	6	PP	WHITE
410721	3	6	PP	BROWN

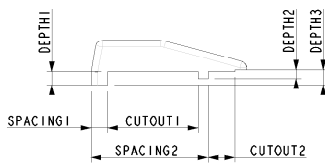
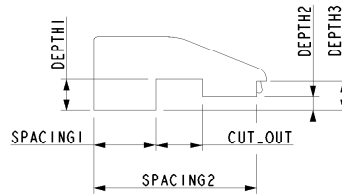
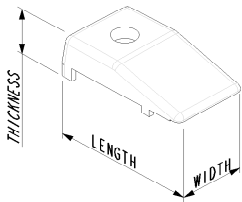
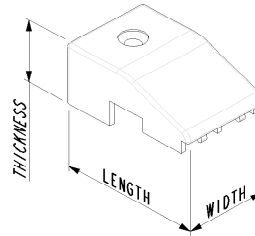

- W** =Width
- D1** =Depth1
- D2** = Depth2
- D3** = Depth3
- T** =Thickness
- L** =Length
- S1** =Spacing 1
- S2** = Spacing 2
- C1** =Cutout1
- C2** =Cutout2

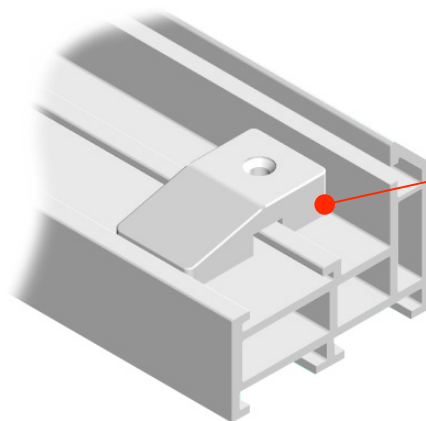

For more information visit:
www.glazpart.com

PARTNo	L	W	T	D	C	MATL	COLOUR
410700	29.5	28	5	3	28.5	PP	WHITE
410701	29.5	28	5	3	28.5	PP	BROWN

PARTNo	L1	W	T	L2	D	C	MATL	COLOUR
410262	40	24.5	13	25.5	3.5	2.5	PP	WHITE
410266	40	24.5	13	25.5	3.5	2.5	PP	BROWN

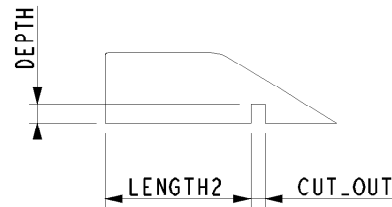
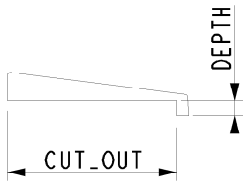
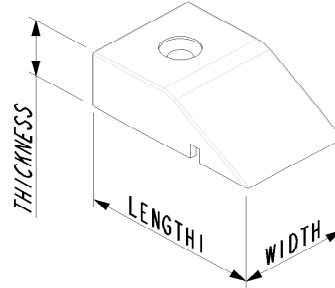
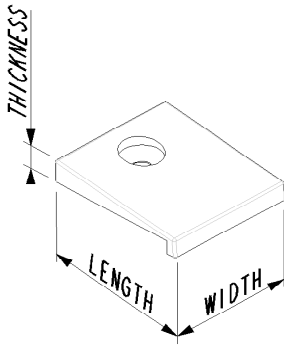

W =Width
T =Thickness
L1 =Length1
L2 = Length2
D = Depth
C = Cutout

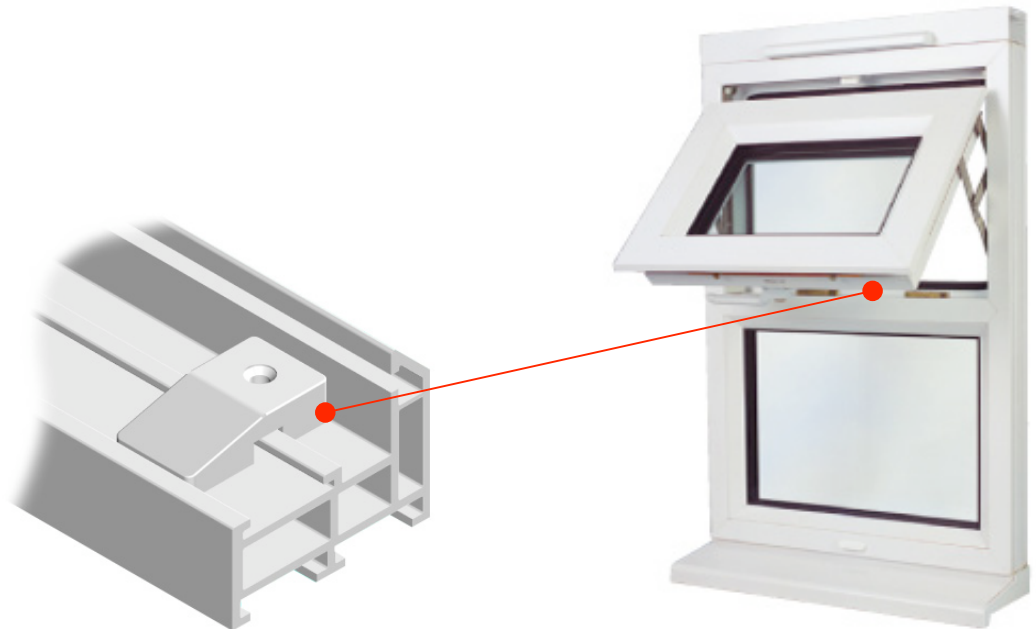

For more information visit:
www.glazpart.com

PARTNo	L1	W	T	L2	D	MATL	COLOUR
410263	40.5	25	14	26.5	3.5	PP	WHITE
410268	40.5	25	14	26.5	3.5	PP	BROWN
410620	44	28	12.8	32	2.8	PP	WHITE
410621	44	28	12.8	32	2.8	PP	BROWN

PARTNo	L1	W	T	L2	D	C	MATL	COLOUR
410264	46.5	25	12	7	10.2	2.6	PP	WHITE
410265	46.5	25	12	7	10.2	2.6	PP	BROWN

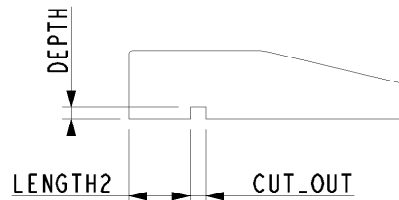
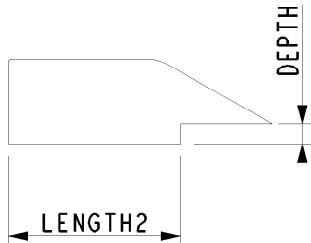
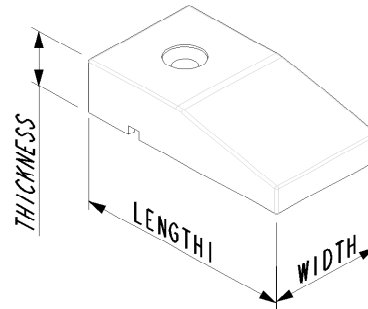
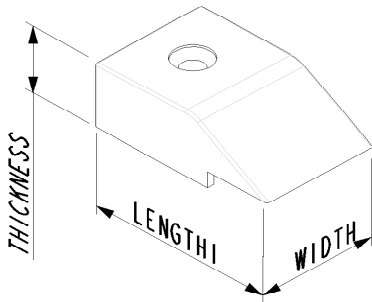

W =Width
T =Thickness
L1 =Length
L2 = Length2
D = Depth
C =Cutout

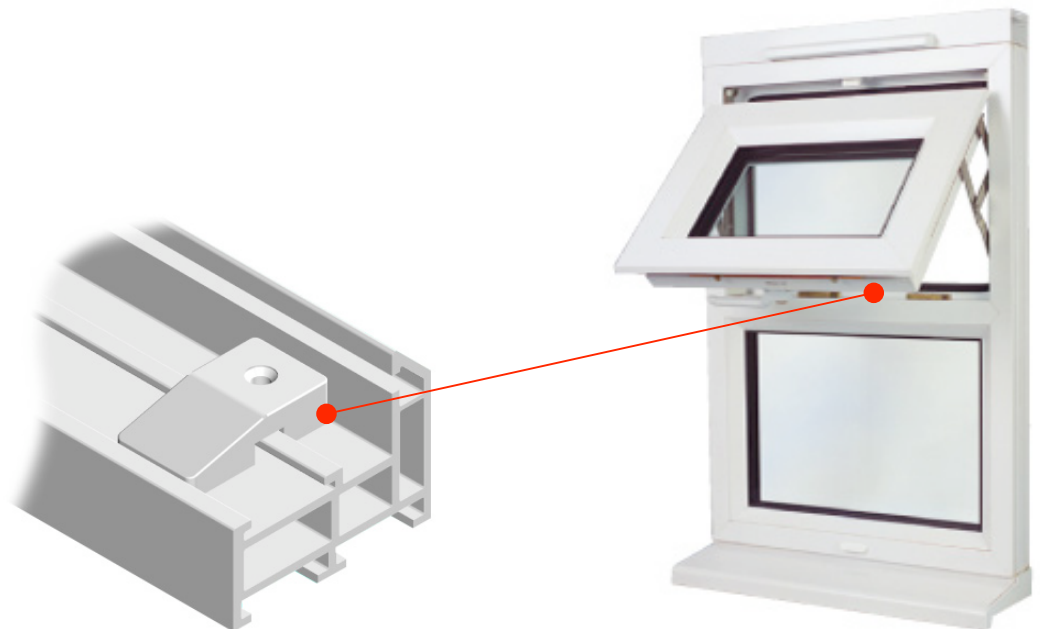

For more information visit:
www.glazpart.com

PARTNo	L	W	T	D1	D2	S1	S2
410267	46	25	12	3.5	2.6	9.6	24.5

PARTNo	C1	C2	MATL	COLOUR
410267	2.6	3	PP	BROWN

PARTNo	L	W	T	D1	D2	D3	S1	S2
410270	40	30	15.3	4	5.8	5.3	4.5	32
410271	40	30	15.3	4	5.8	5.3	4.5	32

PARTNo	S3	C1	MATL	COLOUR
410270	3.5	18	PP	WHITE
410271	3.5	18	PP	BROWN

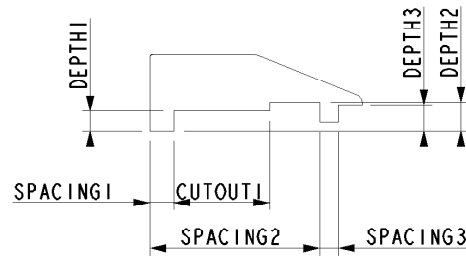
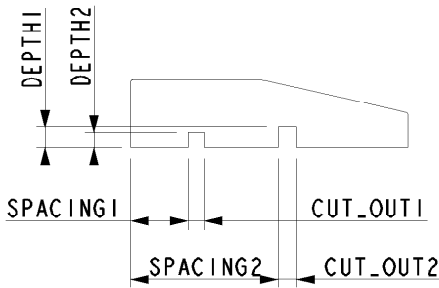
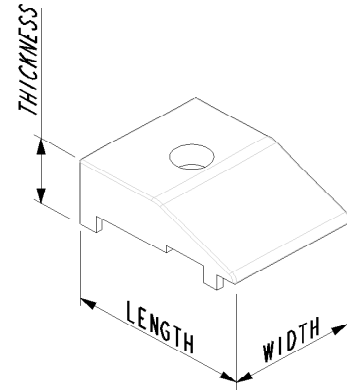
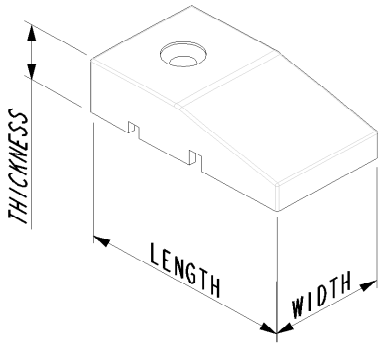

- W =Width
- T =Thickness
- L =Length
- S1 =Spacing 1
- S2 = Spacing 2
- U =Undercut

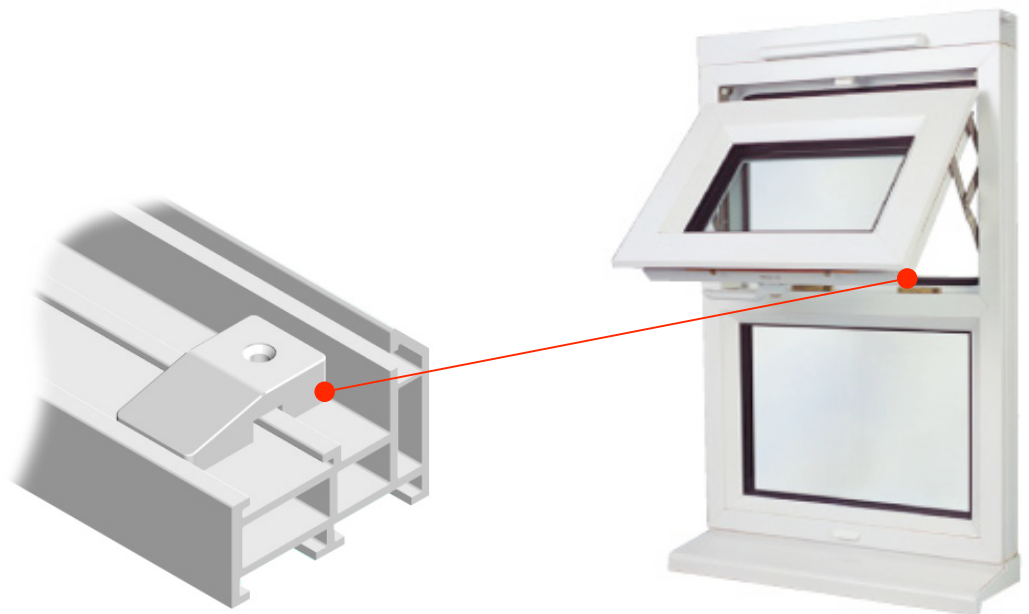

For more information visit:
www.glazpart.com

PARTNo	L	W	T	D1	D2	D3	S1
410290	44.5	28	20	8.5	3.8	8	15.8
410291	44.5	28	20	8.5	3.8	8	15.8

PARTNo	L	W	T	D1	D2	D3	S1
410342	43	30	11.7	4	3	2.4	1.4
410343	43	30	11.7	4	3	2.4	1.4
410344	43	30	11.7	4	3	2.4	1.4

PARTNo	S2	C	MATL	COLOUR
410290	42	12	PP	WHITE
410291	42	12	PP	BROWN

PARTNo	S2	C	MATL	COLOUR
410342	5	22.5	PP	WHITE
410343	5	22.5	PP	BROWN
410344	5	22.5	PP	BLACK

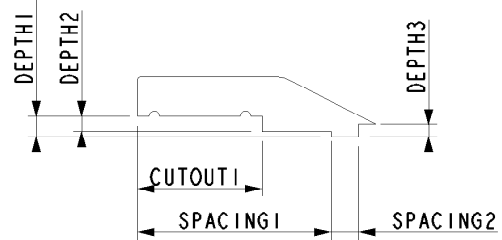
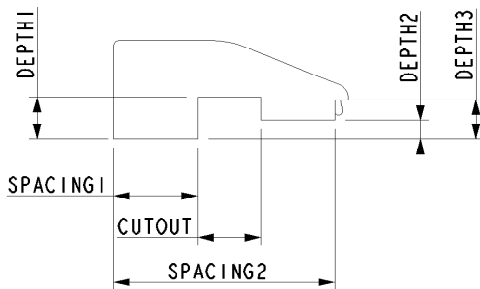
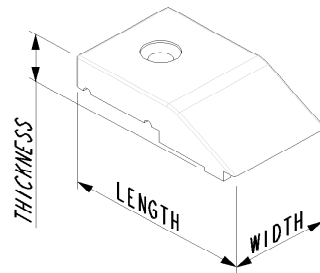
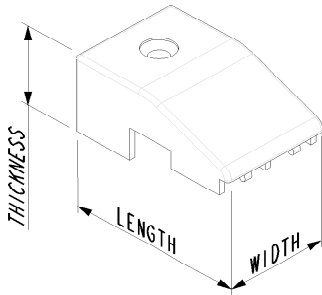

- W =Width
- T =Thickness
- L =Length
- S1 =Spacing1
- S2 = Spacing2
- C = Cutout
- D1 = Depth 1
- D2 = Depth 2
- D3 =Depth3

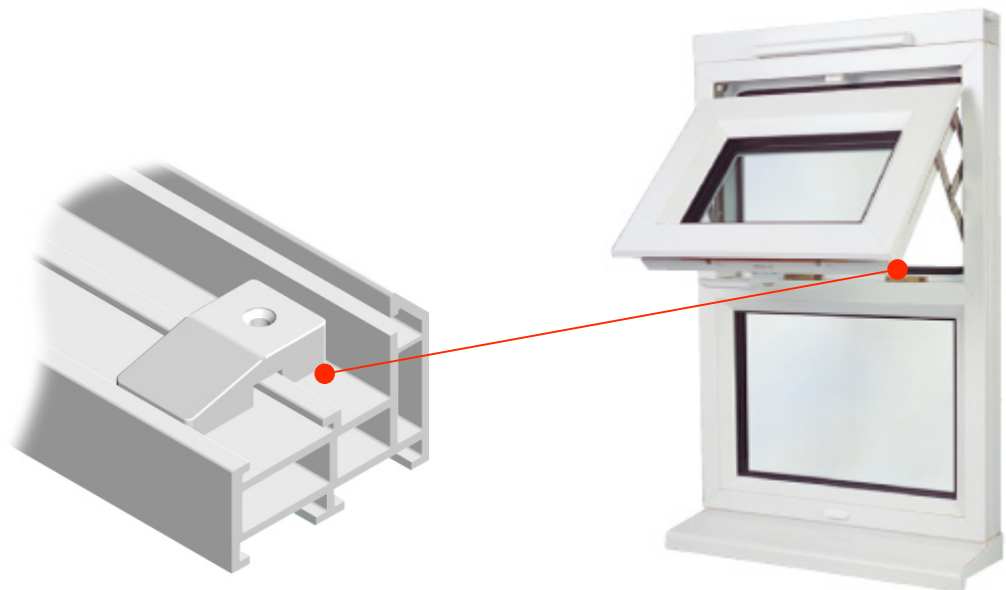

For more information visit:
www.glazpart.com

PARTNo	L	W	T	D1	D2	D3	S1	S2
410451	34.5	30	9.5	5.5	3	5	10.2	15.2

PARTNo	S3	C1	C2	C3	MATL	COLOUR
410451	3.8	2.5	4.3	25.6	PP	WHITE

PARTNo	L	W	T	D1	D2	D3	S1	S2
410351	39.5	29.5	12.8	4.5	2	3	13.3	33.7
410352	39.5	29.5	12.8	4.5	2	3	13.3	33.7

PARTNo	C1	C2	MATL	COLOUR
410351	7.4	3	PP	WHITE
410352	7.4	3	PP	BROWN

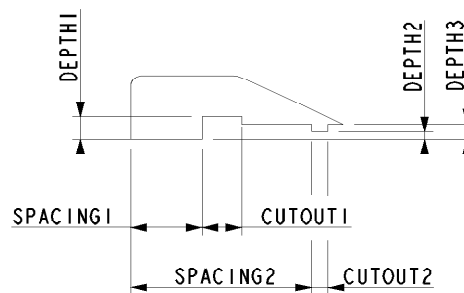
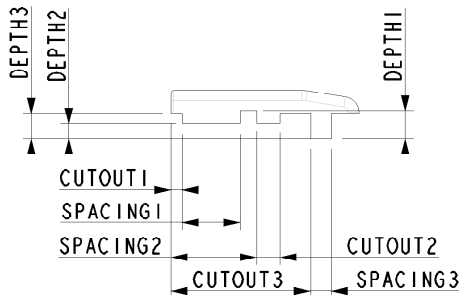
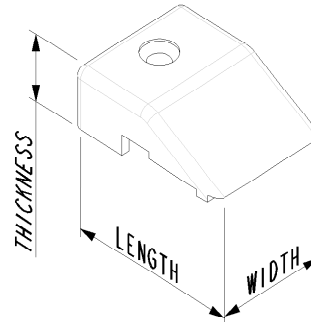
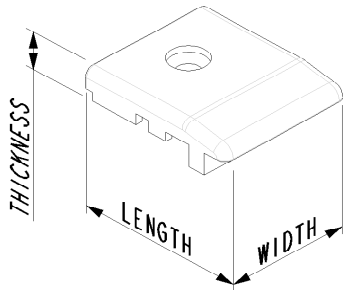

- W =Width
- S1 = Spacing1
- S2 = Spacing2
- S3 = Spacing3
- T =Thickness
- L =Length
- C1 = Cutout1
- C2 = Cutout2
- C3 = Cutout3
- D1 =Spacing 1
- D2 = Spacing 2
- D3 =Undercut

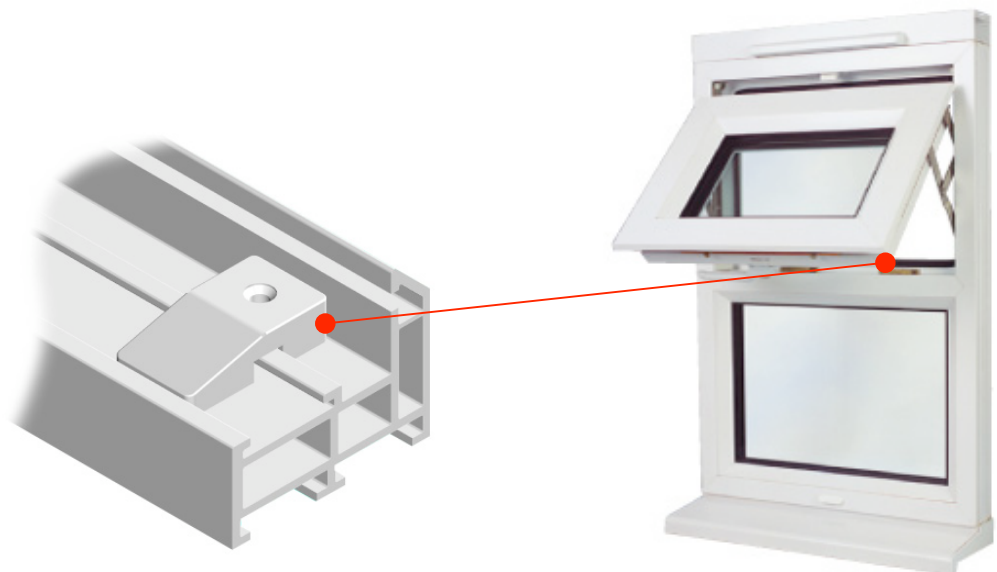

For more information visit:
www.glazpart.com

PARTNo	L	W	T	D1	D2	S	MATL	COLOUR
410454	44	28	17.6	3.3	6.2	23	PP	WHITE
410455	44	28	17.6	3.3	6.2	23	PP	BROWN
410464	44	28	17.6	3.3	6.2	23	PP	BLACK

PARTNo	L	W	T	D1	D2	S1
410456	44	28	17	4	7	17.6
410457	44	28	17	4	7	17.6
410458	44	28	17	4	7	17.6

PARTNo	S2	S3	MATL	COLOUR
410456	22.6	33	PP	WHITE
410457	22.6	33	PP	BROWN
410458	22.6	33	PP	BLACK

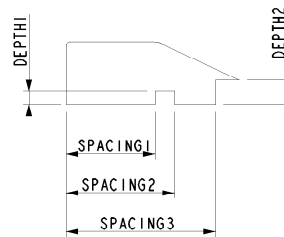
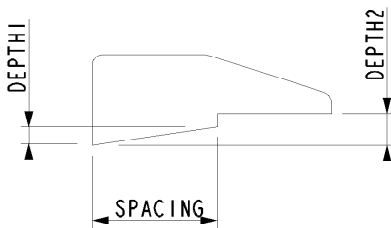
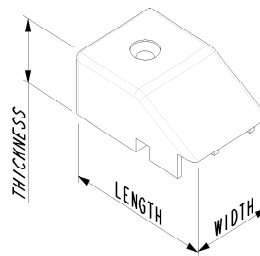
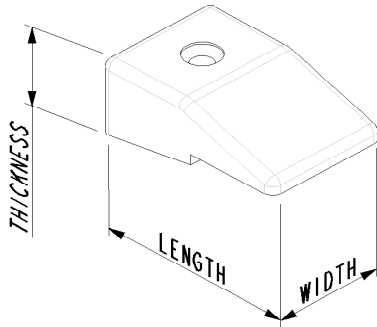

- W =Width
- T =Thickness
- D1 =Spacing 1
- D2 = Depth2
- D3 = Depth3
- L =Length
- S1 = Spacing1
- S2 = Spacing3

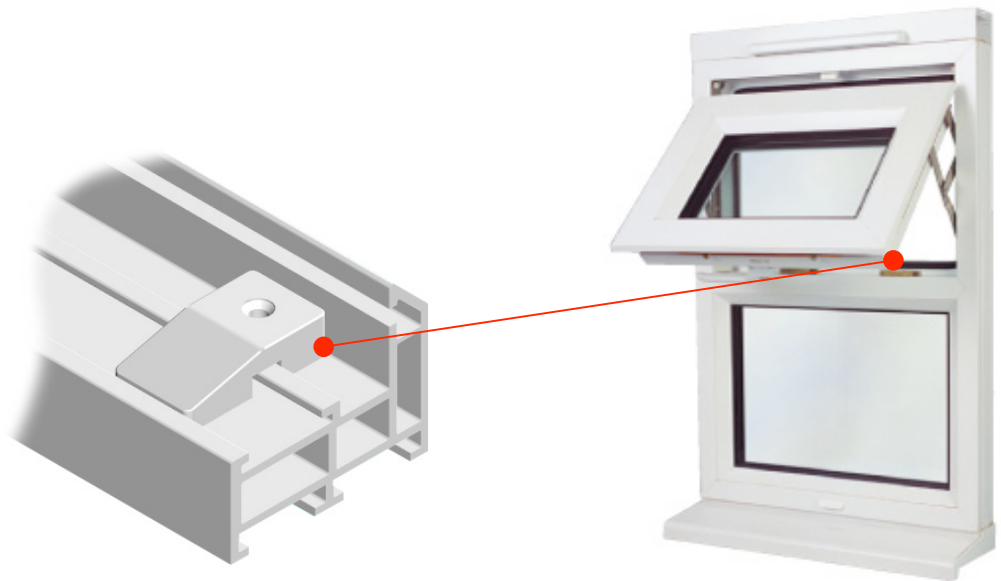

For more information visit:
www.glazpart.com

PARTNo	L1	W	T	D1	D2	L2	C	MATL	COLOUR
920023	35	22	15	4	3	18	3	ABS	WHITE

PARTNo	L	W	T	MATL	COLOUR
920200	42.5	25.5	9	PP	WHITE

W =Width
T =Thickness
D1 = Depth1
D2 = Depth2
L =Length
L2 =Length2
C = Cutout

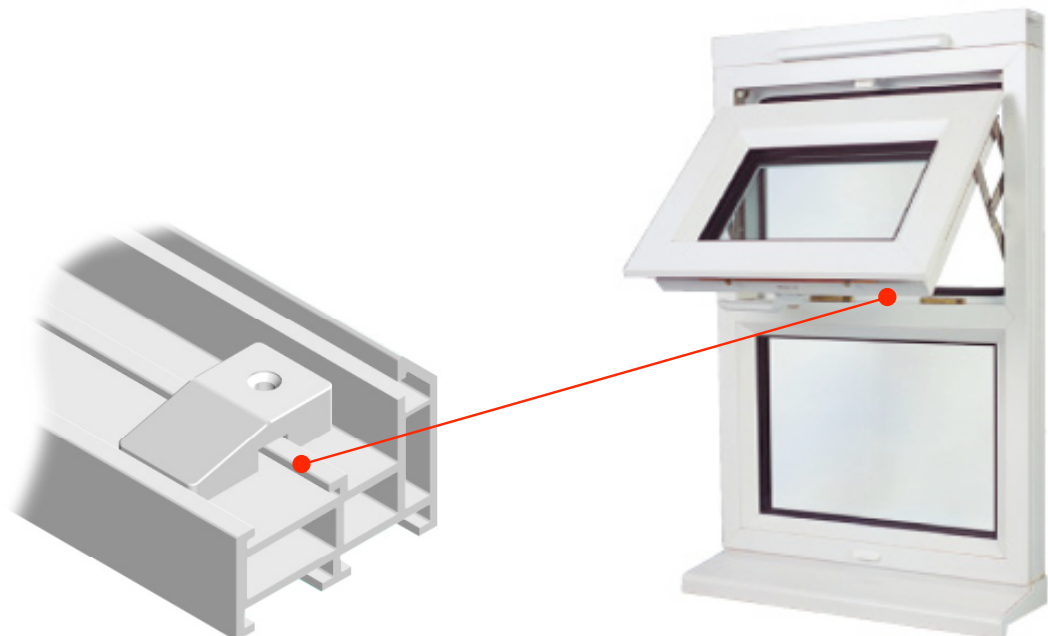
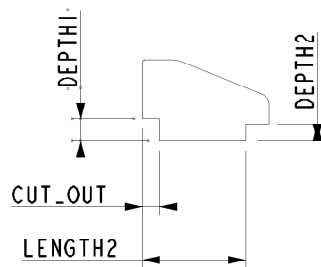
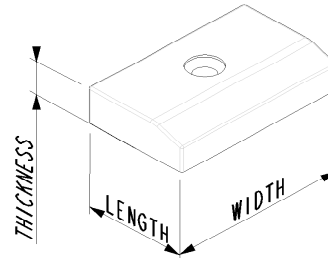
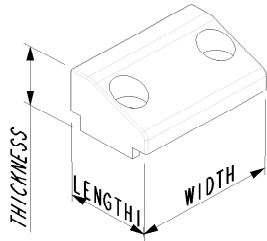

For more information visit:
www.glazpart.com

PARTNo	L	W	T	D1	D2
410460	44	25	17	6	5
410461	44	25	17	6	5

PARTNo	C1	C2	MATL	COLOUR
410460	17.5	23.5	PP	WHITE
410461	17.5	23.5	PP	BROWN

PARTNo	L1	W1	L2	W2	D1	D2
410510	50	22.5	50	11.5	14	14

PARTNo	MATL	COLOUR
410510	PP	WHITE

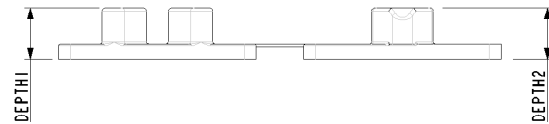
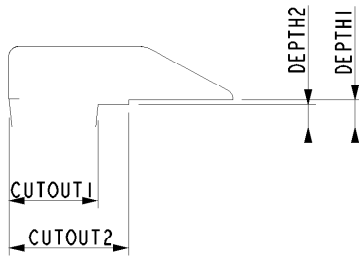
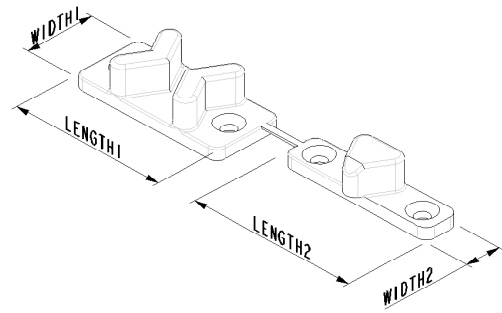
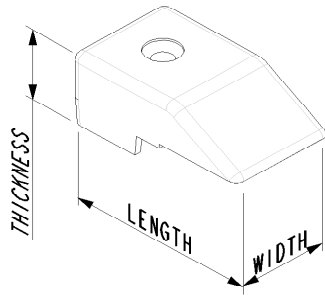

W1 =Width1
W2 =Width2
D1 = Depth1
D2 = Depth2
L1 =Length1
L2 =Length2
C1 = Cutout1
C2 = Cutout2

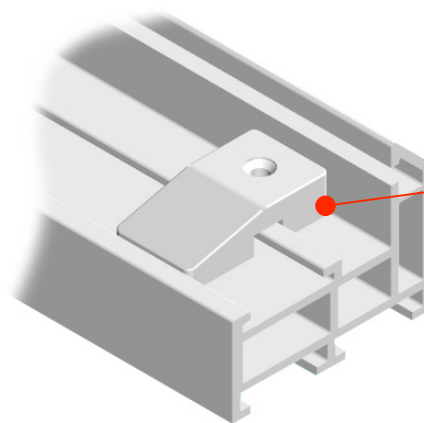

For more information visit:
www.glazpart.com

PARTNo	L	W	T	D1	D2
410220	43.5	26	12.7	3.7	2.7
410231	43.5	26	12.7	3.7	2.7
410660	60	27	15.7	0.9	3
410661	60	27	15.7	0.9	3

PARTNo	S1	S2	S3	MATL	COLOUR
410220	14.5	22.4	18.1	PP	WHITE
410231	14.5	22.4	18.1	PP	BROWN
410660	12.5	30.7	25.3	PP	WHITE
410661	12.5	30.7	25.3	PP	BROWN

PARTNo	L	W	T	D	S1	S2
410230	48	26.5	12.5	4.5	4.3	16.7
410540	53.5	22	15.5	2.7	4	13.7
410541	53.5	22	15.5	2.7	4	13.7

PARTNo	S3	S4	MATL	COLOUR
410230	25.6	18.6	PP	WHITE
410540	27.5	23	PP	WHITE
410541	27.5	23	PP	BROWN

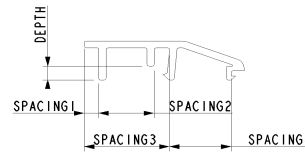
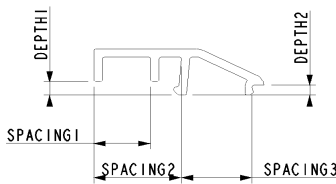
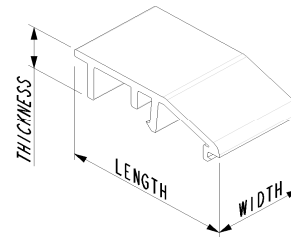
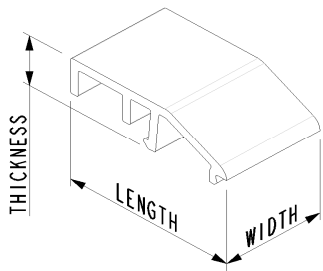

- W = Width**
- L = Length**
- T = Thickness**
- D1 = Depth1**
- D2 = Depth2**
- S1 = Spacing1**
- S2 = Spacing2**
- S3 = Spacing3**
- S4 = Spacing4**

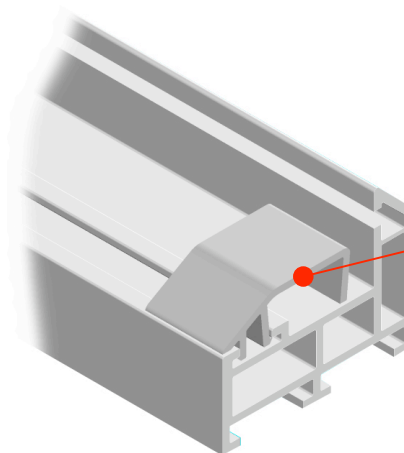

For more information visit:
www.glazpart.com

PARTNo	L	W	T	D1	D2
410481	40	16	10	4	7
410482	40	16	10	4	7
410670	45.5	26.5	17.3	2.8	5.8
410671	45.5	26.5	17.3	2.8	5.8

PARTNo	L	W	T	D	S1'
410501	51.1	17	15.5	5.2	9.9
410502	51.1	17	15.5	5.2	9.9

PARTNo	S1	S2	MATL	COLOUR
410481	11	18.6	PP	WHITE
410482	11	18.6	PP	BROWN
410670	16.2	25.8	PP	WHITE
410671	16.2	25.8	PP	BROWN

PARTNo	S2	S2	MATL	COLOUR
410501	20.8	11.9	NYLON	WHITE
410502	20.8	11.9	NYLON	BROWN

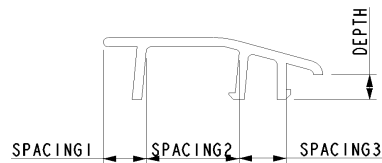
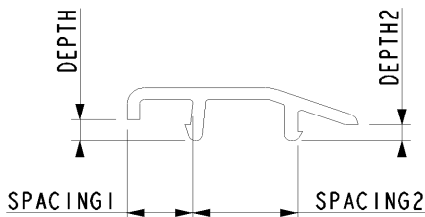
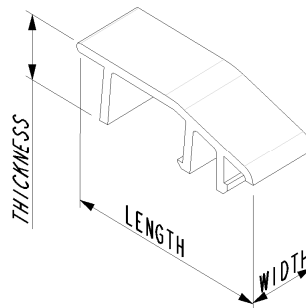
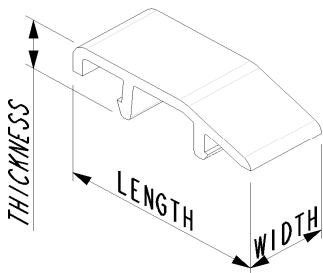

- W = Width
- D1 = Depth1
- D2 = Depth2
- L = Length
- T = Thickness
- S1 = Spacing1
- S2 = Spacing2
- S3 = Spacing3

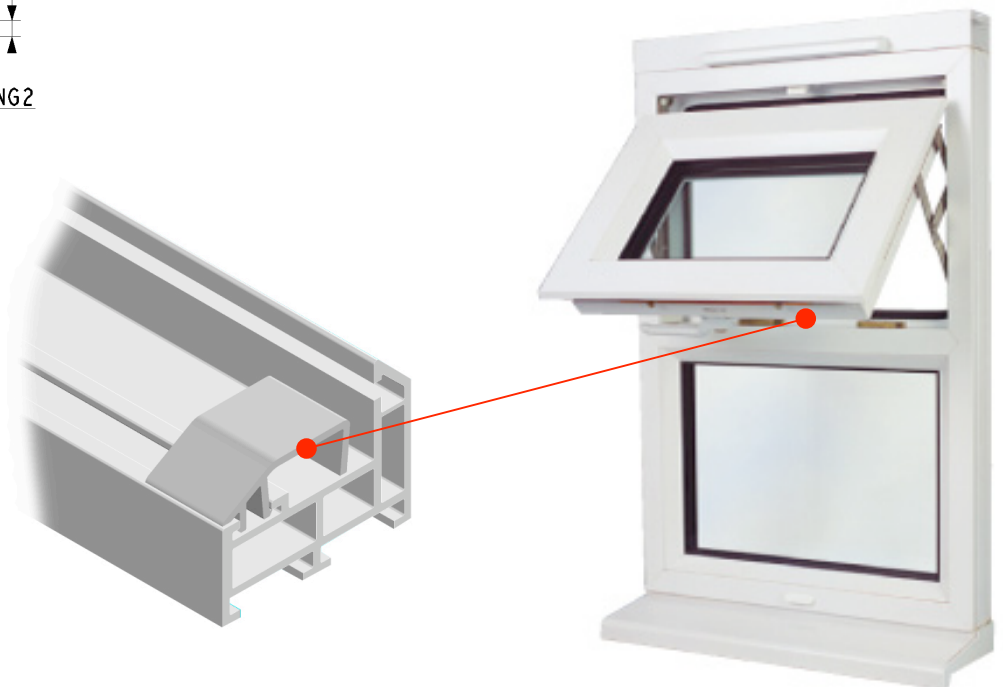

For more information visit:
www.glazpart.com

PARTNo	L	W	T	D1	D2
410491	45	17	13.3	3.3	3.2
410492	45	17	13.3	3.3	3.2
410505	42	17	13.3	3.3	3.2
410506	42	17	13.3	3.3	3.2
410520	50	17	14	0	0
410521	50	17	14	0	0
410530	46	22	12.2	0.7	0.5

PARTNo	L	W	T	D	S1
410570	50	27	11	2.4	26.4

PARTNo	S2	MATL	COLOUR
410570	20.4	PP	WHITE

PARTNo	S1	S2	S3	MATL	COLOUR
410491	8.9	14.2	18.9	PP	WHITE
410492	8.9	14.2	18.9	PP	BROWN
410505	8.9	8.7	23.5	NYLON	WHITE
410506	8.9	8.7	23.5	NYLON	BROWN
410520	7.1	21	19	PP	WHITE
410521	7.1	21	19	PP	BROWN
410530	6	16.3	20.2	PP	WHITE

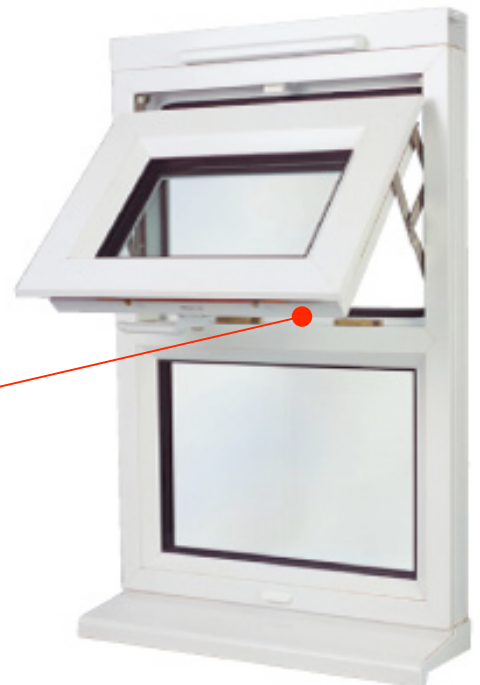
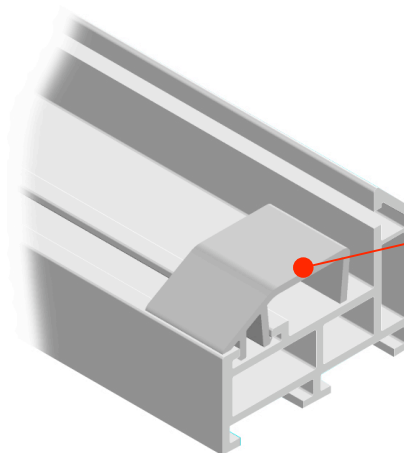
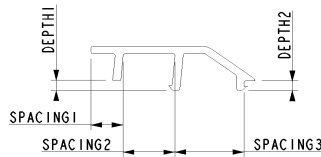
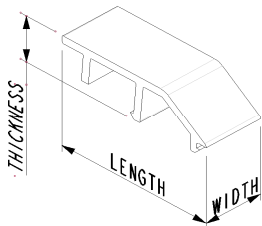
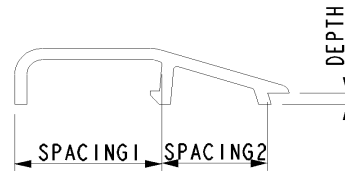
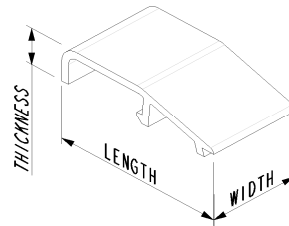

W = Width
D1 = Depth1
D2 = Depth2
L = Length
T = Thickness
S1 = Spacing1
S2 = Spacing2
S3 = Spacing3



For more information visit:
www.glazpart.com

PARTNo	L	W	T	D1
410580	54	22	15.4	3.4
410581	54	22	15.4	3.4

PARTNo	S1	S2	MATL	COLOUR
410580	31	17.5	PP	WHITE
410581	31	17.5	PP	BROWN

PARTNo	L	W	T	D1	D2
410601	40	26.6	14.2	2.7	5.8

PARTNo	S1	S2	MATL	COLOUR
410601	2.5	32	NYLON	WHITE

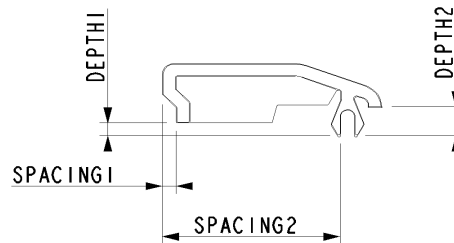
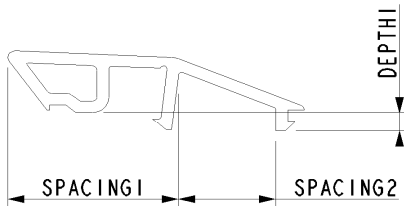
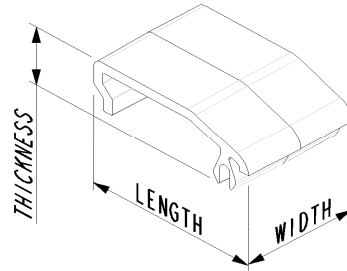
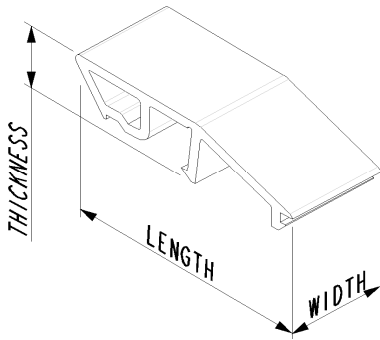

W = Width
D = Depth
L = Length
T = Thickness
S1 = Spacing1
S2 = Spacing2

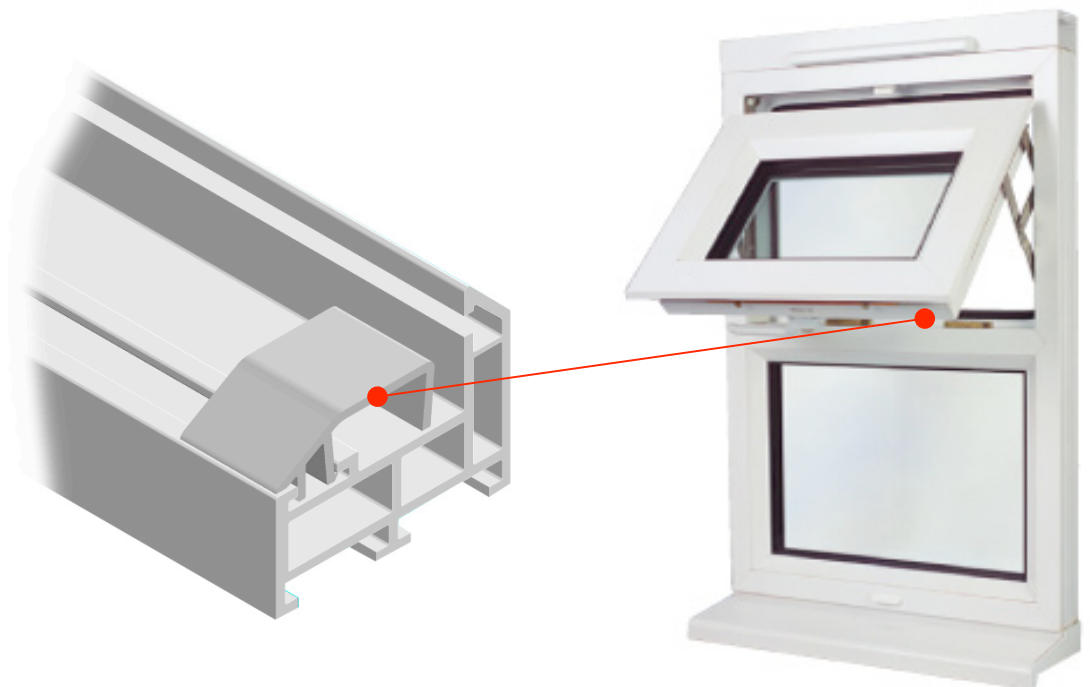

For more information visit:
www.glazpart.com

PARTNo	L	W	T	D
410730	44	26.5	17	0.8
410731	44	26.5	17	0.8

PARTNo	L	W	T	S1	S2	MATL	COLOUR
410970	50	30	14.2	27.8	21	PP	WHITE

PARTNo	S1	S2	MATL	COLOUR
410730	28.5	9.3	PP	WHITE
410731	28.5	9.3	PP	BROWN

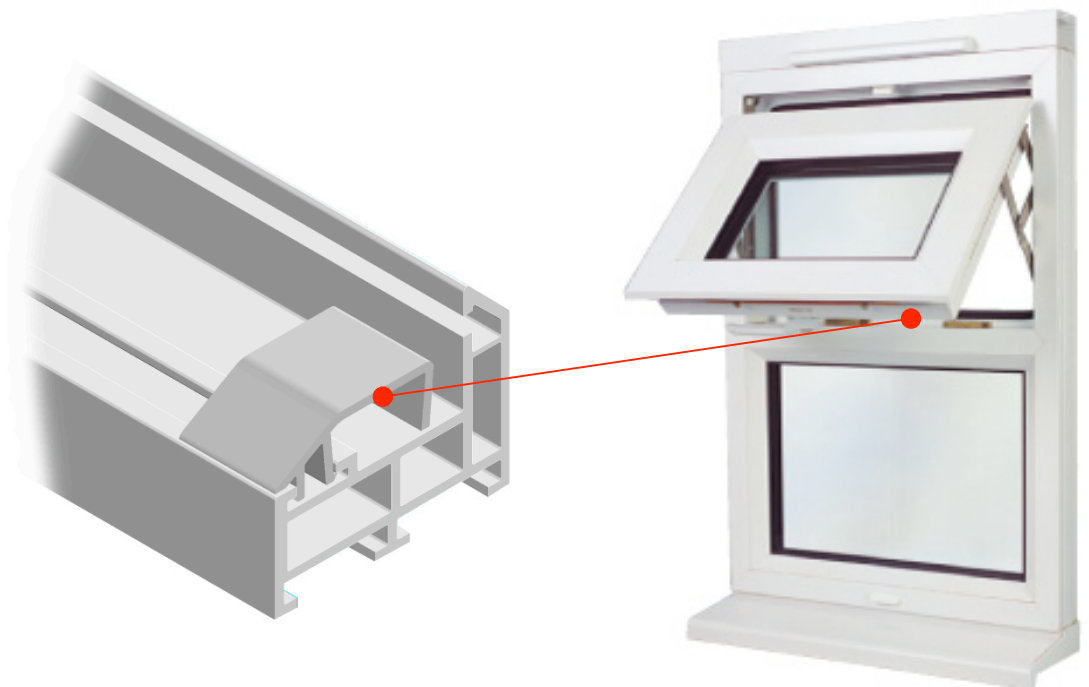
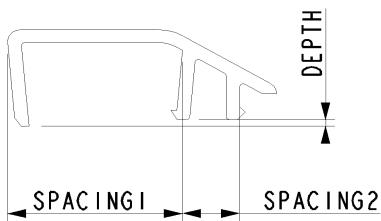
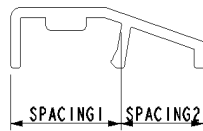
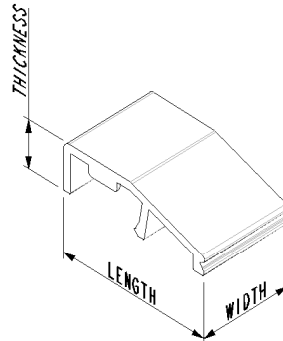
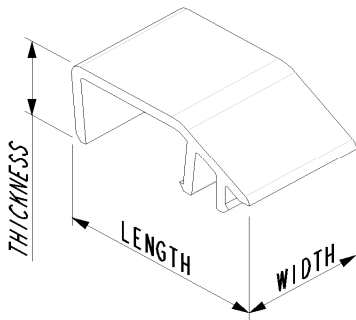

W = Width
D = Depth
L = Length
T = Thickness
S1 = Spacing1
S2 = Spacing2



For more information visit:
www.glazpart.com